

PVC-U Butterfly valves PROFLOW® H PVC-U Valvole a farfalla PROFLOW® H

Rev. Mar 2021



High performance butterfly valve for closing or flow regulating applications. Greater flow rates and reduced pressure drop across the valve, along with fine control, integral seal and ease of actuation means the PROFLOW H butterfly valve is ideal for high performance applications.

Valvola a farfalla ad alte prestazioni per intercettazione o regolazione del flusso. Le maggiori portate e le ridotte perdite di carico attraverso la valvola, il controllo preciso, la guarnizione integrale e la facilità di attuazione rendono la valvola a farfalla PROFLOW H ideale per applicazioni ad alta prestazione.

- Patented High Flow offset disc with a unique design to allow for a greater flow rate and lower pressure drop in comparison to traditional discs, and a linear response resulting in greater control and excellent flow regulation.

Disco brevettato per garantire maggiore portata e minori perdite di carico rispetto ai dischi tradizionali e consentire una risposta lineare con conseguente miglior controllo ed eccellente regolazione del flusso.

- Integral seal made of certified EPDM and machined PVC-U body to guarantee a secure seal.

Guarnizione integrale in EPDM certificato e corpo in PVC-U lavorato, per garantire una perfetta tenuta.

- Zinc plated carbon steel stem, square according to ISO 5211.

Asta in acciaio zincato, a estremità quadra secondo ISO 5211.

- Regulating plate with 19 positions between 0° and 90°, for fine readjustment of the flow rate.

Regolazione fine della portata, con 19 posizioni tra 0° e 90°.

- Suitable for installation between EN/ISO/DIN, ANSI and JIS flanges.

Adatta per l'installazione con flange EN/ISO/DIN, ANSI e JIS.

- Fit for contact with potable water.

Adatta per il contatto con acqua potabile.

- Compliant with the requirements of Pressure Equipment Directive 2014/68/EU, Annex III, Module A2.

Conforme ai requisiti della Direttiva Europea 2014/68/EU sulle attrezzature a pressione, Allegato III, Modulo A2.



TECHNICAL FEATURES / CARATTERISTICHE TECNICHE

NOMINAL PRESSURE / PRESSIONE NOMINALE	PN 10 (145 psi) 20°C
DIMENSIONS / DIMENSIONI	DN 65 ÷ DN 200 (d.75 ÷ 200/225 mm; 2"1/2 ÷ 8")
VALVE MATERIAL / MATERIALE VALVOLA	PVC-U
SEALS MATERIAL / MATERIALE GUARNIZIONI	EPDM, EPDM NSF Certified on request / EPDM Certificato NSF a richiesta
TEMPERATURE RANGE / TEMPERATURA	0°C ÷ 60°C
STEM MATERIAL / MATERIALE ASTA	Zinc plated carbon steel / Acciaio zincato
COUPLING STANDARDS / GIUNZIONI	Flanging system, drilled to: / Flangiatura, con foratura secondo: EN ISO 1452, EN ISO 15493, DIN 2501, EN 1092-1; ASTM B16.5; JIS B2220
CONTROL OPTIONS / OPZIONI DI COMANDO	Hand-operated / Manuale Wheel gearbox / Manuale con riduttore a volantino Electrically actuated / Comando elettrico Pneumatically actuated / Comando pneumatico



EPDM NSF certified available on request / EPDM certificato NSF disponibile a richiesta

Certifications and approvals: only for items declared on Official Listing or certificates. / Certificazioni: solo per gli articoli dichiarati nelle Official Listing o nei certificati stessi.

EFFAST

PVC-U Butterfly valves PROFLOW® H PVC-U Valvole a farfalla PROFLOW® H



Operating pressure / Pressione di esercizio

Maximum operating pressure for PVC-U: according to temperature as shown in graph.

Massima pressione di esercizio per il PVC-U: secondo quanto indicato nel grafico in figura.

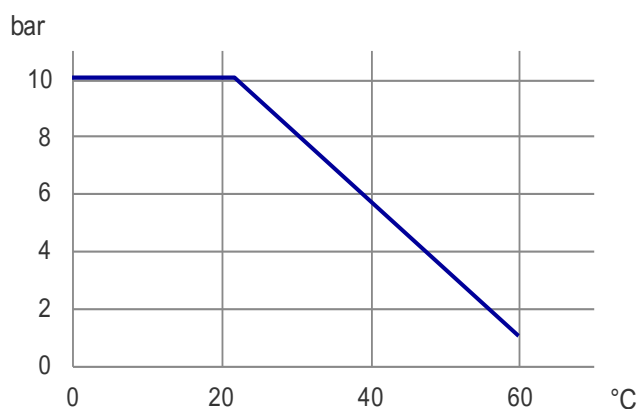

Pressure loss / Perdite di carico

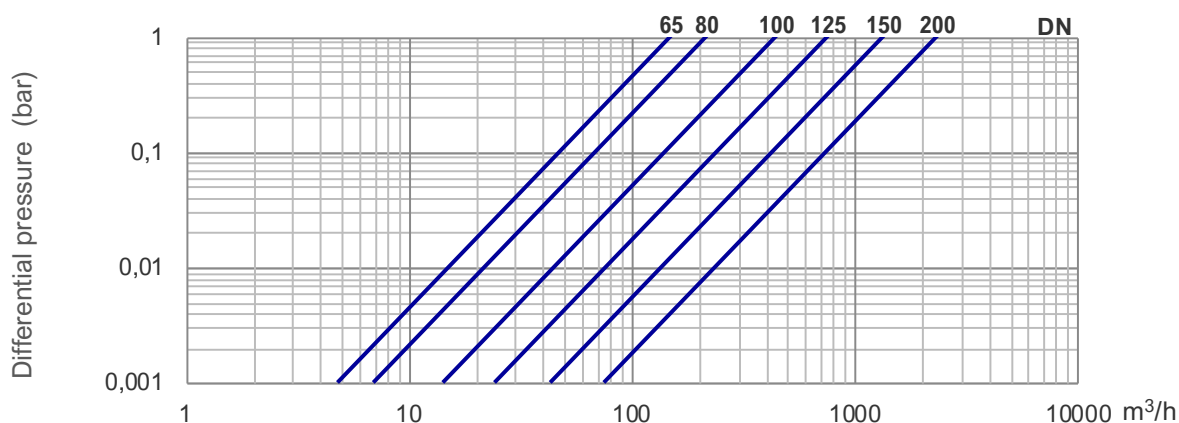

Flow rate coefficient Kv100 / Coefficiente di flusso Kv100

At $\Delta p = 1$ bar.

Kv100 flow coefficient is the flow rate of water at 20°C that will generate 1 bar pressure drop. The Kv100 values in the table are calculated for the valve completely open.

Per $\Delta p = 1$ bar.

Il coefficiente di flusso Kv100 è la portata dell'acqua a 20° che genera una caduta di pressione di 1 bar. I valori del coefficiente Kv100 riportati nella tabella sono riferiti alla valvola completamente aperta.

DN	65	80	100	125	150	200
m ³ /h	153	219	456	775	1368	2371

Torque force at maximum/minimum pressure rate / Coppia di manovra alla massima/minima pressione

DN	65	80	100	125	150	200
At min PFA rate (Nm)	10	15	20	46	70	90
At max PFA rate (Nm)	25	28	35	53	88	140

Actuation / Attuazione

PROFLOW butterfly valve can be actuated with standard electric or pneumatic actuators and can be equipped with wheel gearboxes. The mounting flange is drilled according to standard ISO 5211. No additional kit is needed.

La valvola a farfalla PROFLOW può essere azionata mediante attuatori elettrici o pneumatici standard e può essere dotata di riduttore a volantino. Lo standard di accoppiamento è conforme allo standard ISO 5211. Non sono necessari kit aggiuntivi.

DN	ISO 5211	A	d	Q	H
65	F07	70	9	14	16
80	F07	70	9	14	16
100	F07	70	9	14	16
125	F07	70	9	14	16
150	F07/F10	70/102	9/11	17	19
200	F07/F10	70/102	9/11	22	24

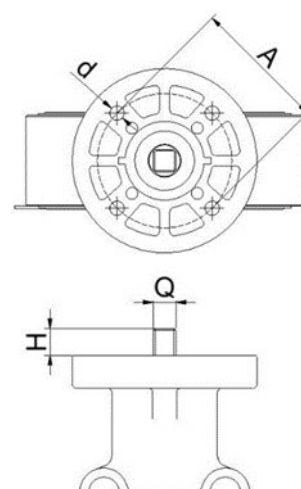

Flanged coupling / Accoppiamento flange

Before installing the valve, check that the bore of the fixed flange/stub allows the valve disc to open correctly. Refer to dimension Q (see dimensional sheets) for the minimum bore needed.

PROFLOW H valve is compatible with the following standards for flanges:

Prima di installare la valvola, verificare che il foro della flangia fissa/del collare permetta al disco di ruotare e aprirsi correttamente. Fare riferimento alla dimensione Q (vedi scheda dimensionale) per il minimo alesaggio necessario.

La valvola a farfalla PROFLOW H è compatibile con flange conformi ai seguenti standard:

DN	d (mm)	d (in)	EN/ISO/DIN PN10	ANSI 150 lb	JIS 10K
65	75	2"1/2	✓✓	✓✓	✓✓
80	90	3"	✓	✓✓	✓
100	110	4"	✓	✓	✓
125	125/140	5"	✓	✓	✓
150	160	6"	✓	✓	✓
200	200/225	8"	✓	✓	✓

✓✓ full drilled - ✓ partially drilled

Components / Componenti

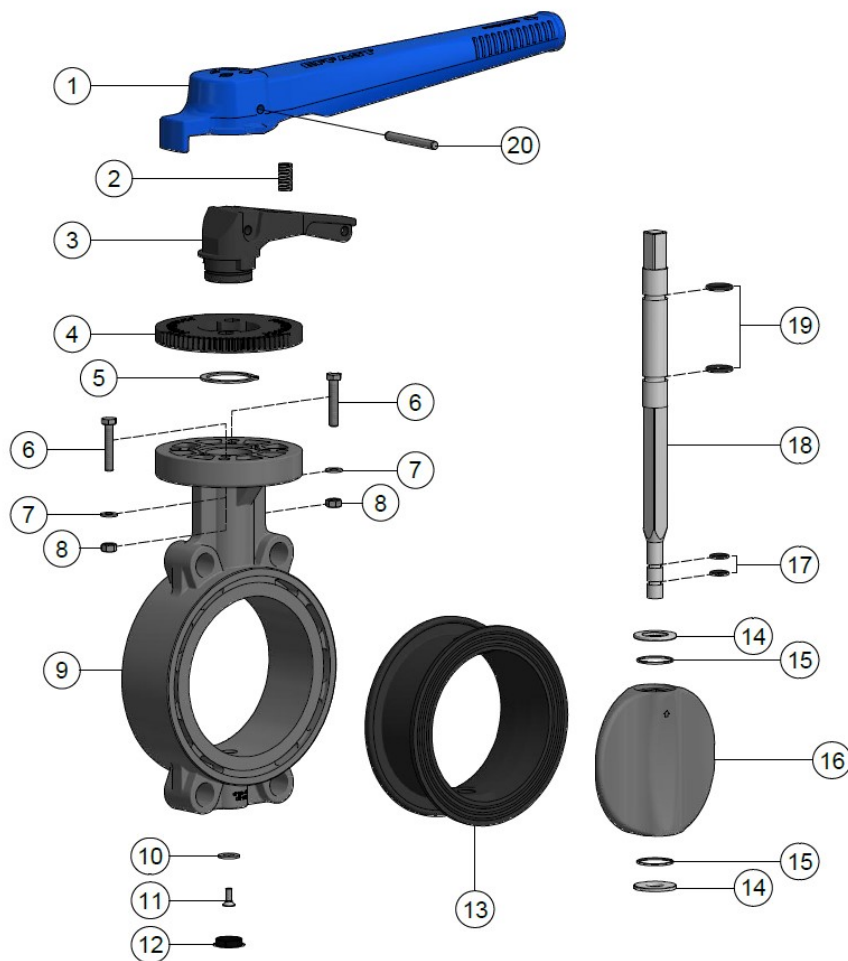

n.	COMPONENT	MATERIAL	Qty
1	Handle / <i>Maniglia</i>	ABS	1
2	Spring / <i>Molla</i>	Steel / <i>Acciaio</i>	1
3	Handle support / <i>Supporto maniglia</i>	PA6 30GF	1
4	Regulating plate / <i>Piatto di regolazione</i>	PA6 30GF	1
5	Retaining ring / <i>Anello di arresto</i>	Zinc-plated steel / <i>Acciaio zincato</i>	1
6	Screw / <i>Vite</i>	Zinc-plated steel / <i>Acciaio zincato</i>	2
7	Washer / <i>Rondella piana</i>	Zinc-plated steel / <i>Acciaio zincato</i>	2
8	Nut / <i>Dado esagonale</i>	Zinc-plated steel / <i>Acciaio zincato</i>	2
9	Body / <i>Corpo</i>	PVC-U	1
10	Washer / <i>Rondella piana</i>	Zinc-plated steel / <i>Acciaio zincato</i>	1

n.	COMPONENT	MATERIAL	Qty
11	Screw / <i>Vite</i>	Zinc-plated steel / <i>Acciaio zincato</i>	1
12	Cap / <i>Tappo</i>	HDPE	1
13	Liner / <i>Guarnizione</i>	EPDM	1
14	Disc seal ¹ / <i>Tenuta disco</i> ¹	PTFE	2
15	Disc O-ring ¹ / <i>O-ring disco</i> ¹	EPDM	2
16	Disc / <i>Disco</i>	PVC-U	1
17	Stem O-ring / <i>O-ring asta</i>	EPDM	2
18	Stem / <i>Asta</i>	Zinc-plated steel / <i>Acciaio zincato</i>	1
19	Stem O-rings / <i>O-ring asta</i>	EPDM	2
20	Straight pin / <i>Spina</i>	Zinc-plated steel / <i>Acciaio zincato</i>	1

1) From DN 125 to DN 200 / *Da DN 125 a DN 200*

All descriptions and illustrations in this publication are intended for guidance only and shall not constitute a 'sale by description'. All dimensions given are nominal, while changes can be done on the information, products and specifications from time to time for a variety of reasons, without prior notice. The information in this publication is provided 'as is' on the revision date stated on the sheet. Updates will not be issued automatically. This information is not intended to have any legal effect, whether by way of advice, representation or warranty (express or implied). We accept no liability whatsoever (to the extent permitted by law) if you place any reliance on this publication you must do so at your own risk. All rights reserved. Copyright in this publication belongs to Polypipe Italia and all such copyright may not be used, sold, copied or reproduced in whole or part in any manner in any media to any person without prior consent. **EFFAST** is a registered trademark."